

ICS 13.220.20

English version

Fire detection and fire alarm systems — Part 3: Fire alarm devices — Sounders

Systèmes de détection et d'alarme incendie —
Partie 3: Dispositifs sonores d'alarme feu

Brandmeldeanlagen — Teil 3: Akustische
Alarmierungseinrichtungen

This European Standard was approved by CEN on 17 December 1999. Amendment A1 was approved by CEN on 5 April 2002 and Amendment A2 was approved by CEN on 27 April 2006.

CEN members are bound to comply with the CEN/CENELEC Internal Regulations which stipulate the conditions for giving this European Standard the status of a national standard without any alteration. Up-to-date lists and bibliographical references concerning such national standards may be obtained on application to the Management Centre or to any CEN member.

This European Standard exists in three official versions (English, French, German). A version in any other language made by translation under the responsibility of a CEN member into its own language and notified to the Management Centre has the same status as the official versions.

CEN members are the national standards bodies of Austria, Belgium, Czech Republic, Denmark, Finland, France, Germany, Greece, Iceland, Ireland, Italy, Luxembourg, Netherlands, Norway, Portugal, Spain, Sweden, Switzerland and United Kingdom.



EUROPEAN COMMITTEE FOR STANDARDIZATION
COMITÉ EUROPÉEN DE NORMALISATION
EUROPÄISCHES KOMITEE FÜR NORMUNG

Management Centre: rue de Stassart, 36 B-1050 Brussels

Contents

	Page
Foreword	4
Introduction	5
1 Scope	6
2 Normative references	6
3 Terms and definitions	7
4 Requirements	7
4.1 Compliance	7
4.2 Sound level	7
4.3 Frequency and sound pattern	7
4.4 Durability	7
4.5 Construction	8
4.6 Marking and data	8
5 Tests	9
5.1 General	9
5.2 Reproducibility	10
5.3 Operational performance	11
5.4 Durability	13
5.5 Dry heat (operational)	13
5.6 Dry heat (endurance)	14
5.7 Cold (operational)	14
5.8 Damp heat, cyclic (operational)	15
5.9 Damp heat, steady state (endurance)	16
5.10 Damp heat, cyclic (endurance)	16
5.11 Sulfur dioxide (SO ₂) corrosion (endurance)	17
5.12 Shock (operational)	18
5.13 Impact (operational)	19
5.14 Vibration, sinusoidal (operational)	19
5.15 Vibration, sinusoidal (endurance)	20
5.16 Electromagnetic compatibility (EMC), immunity (operational)	21
5.17 Enclosure protection	22
Annexes	24
Annex A (normative) Sound level test for fire alarm sounders	24
A.1 General	24
A.2 Mounting arrangements	24
A.3 Instrumentation	24
A.4 Background noise level	24
A.5 Measurement of sound level	24
Annex B (normative) Comparative sound level test during environmental conditioning	27
B.1 General	27
B.2 Test chamber	27
B.3 Mounting arrangements	28
B.4 Instrumentation	28
B.5 Background noise level	28
B.6 Test procedure	28

Annex C (normative) Audible fire alarm devices — Voice sounders.....	31
C.1 Voice sounder.....	31
C.2 General requirements.....	31
C.3 Additional requirements.....	31
C.4 General testing.....	32
C.5 Additional testing for voice sounders.....	32
Annex ZA (informative) Clauses of this European Standard addressing the provisions of the EU Construction Products Directive (89/106/EEC).....	35
ZA.1 Scope and relevant clauses.....	35
ZA.2 Procedures for the attestation of conformity of sounders covered by this standard	36
ZA.3 CE marking and labelling and accompanying documentation	40
ZA.4 EC Certificate and declaration of conformity	41
Bibliography.....	43

Foreword

This European Standard has been prepared by Technical Committee CEN/TC 72, Fire detection and fire alarm systems, the Secretariat of which is held by BSI.

EN 54 is published in a series of parts. Information on the relationship between this European Standard and other standards of the EN 54 series is given in annex A of EN 54-1:1996.

This European Standard shall be given the status of a national standard, either by publication of an identical text or by endorsement, at the latest by October 2001, and conflicting national standards shall be withdrawn at the latest by October 2003. For products which have complied with the relevant national standard before the date of withdrawal (dow), as shown by the manufacturer or by a certification body, this previous standard may continue to apply for production until October 2006.

This standard has been prepared in co-operation with the CEA (Comité Européen des Assurances) and with EURALARM (Association of European Manufacturers of Fire and Intruder Alarm Systems).

This European Standard has been prepared under a mandate given to CEN by the European Commission and the European Free Trade Association, and supports essential requirements of EU Directive(s).

According to the CEN/CENELEC Internal Regulations, the national standards organizations of the following countries are bound to implement this European Standard: Austria, Belgium, Czech Republic, Denmark, Finland, France, Germany, Greece, Iceland, Ireland, Italy, Luxembourg, Netherlands, Norway, Portugal, Spain, Sweden, Switzerland and the United Kingdom.

Foreword to amendment A1

This document EN 54-3:2001/A1:2002 has been prepared by Technical Committee CEN/TC 72, Fire detection and fire alarm systems, the Secretariat of which is held by BSI.

This amendment to the European Standard EN 54-3:2001 shall be given the status of a national standard, either by publication of an identical text or by endorsement, at the latest by December 2002, and conflicting national standards shall be withdrawn at the latest by June 2005.

This document has been prepared under a mandate given to CEN by the European Commission and the European Free Trade Association, and supports essential requirements of the Construction Products Directive (89/106/EEC).

For relationship with EU Directive(s), see informative annex ZA which is an integral part of this document.

According to the CEN/CENELEC Internal Regulations, the national standards organizations of the following countries are bound to implement this European Standard: Austria, Belgium, Czech Republic, Denmark, Finland, France, Germany, Greece, Iceland, Ireland, Italy, Luxembourg, Malta, Netherlands, Norway, Portugal, Spain, Sweden, Switzerland and the United Kingdom.

Foreword to amendment 2

This document (EN 54-3:2001/A2:2006) has been prepared by Technical Committee CEN/TC 72 "Fire detection and fire alarm systems", the secretariat of which is held by BSI.

This Amendment to the European Standard EN 54-3:2001 shall be given the status of a national standard, either by publication of an identical text or by endorsement, at the latest by November 2006, and conflicting national standards shall be withdrawn at the latest by May 2009.

This document has been prepared under a mandate given to CEN by the European Commission and the European Free Trade Association, and supports essential requirements of EU Directive(s).

For relationship with EU Directive(s), see informative Annex ZA, which is an integral part of this document.

Amendment 2 to this standard adds requirements for voice sounders. This involves changes to the Scope of the standard and to the definition of "fire alarm sounder" and the addition of a normative annex, Annex C. Amendment 2 also incorporates an updated version of Annex ZA that lists the performance and test requirements pertinent to voice sounders.

According to the CEN/CENELEC Internal Regulations, the national standards organizations of the following countries are bound to implement this European Standard: Austria, Belgium, Cyprus, Czech Republic, Denmark, Estonia, Finland, France, Germany, Greece, Hungary, Iceland, Ireland, Italy, Latvia, Lithuania, Luxembourg, Malta, Netherlands, Norway, Poland, Portugal, Romania, Slovakia, Slovenia, Spain, Sweden, Switzerland and United Kingdom.

Introduction

The purpose of a fire alarm sounder is to warn person(s) within, or in the vicinity of, a building of the occurrence of a fire emergency situation in order to enable such person(s) to take appropriate measures.

This standard recognizes that the exact nature of the sound requirement, i.e. its frequency range, temporal pattern and output level will vary according to the nature of the installation, the type of risk present and appropriate measures to be taken, the type of signals used for other non-fire emergency alarms (see, for example, EN 457) and national differences in custom and practice. The resulting standard specifies, therefore, a common method for the testing of the operational performance of sounders against the specification declared by the manufacturer rather than imposing common requirements.

Attention is drawn to ISO 8201:1987, *Acoustics — Audible emergency evacuation signal*, the international standard which specifies the temporal pattern and the required sound pressure level of an audible emergency evacuation signal.

This standard gives common requirements for the construction and robustness of sounders as well as for their performance under climatic, mechanical and electrical interference conditions which are likely to occur in the service environment. The sounders have been classified in either an indoor or an outdoor application environment category.

In fire detection and fire alarm systems, voice sounders are used as alarm devices for warning the occupants of a building of the occurrence of a fire risk, using a combination of an attention drawing signal and dedicated voice message(s).

The requirements, test methods and performance criteria specified in EN 54-3:2001 for sounders are also applicable to voice sounders. Additional requirements, test methods and performance criteria specific to voice sounders are incorporated in a normative Annex C.

1 Scope

This European Standard specifies the requirements, test methods and performance criteria for fire alarm sounders in a fixed installation intended to signal an audible warning of fire between a fire detection and fire alarm system and the occupants of a building. It is intended to cover only those devices which derive their operating power by means of a physical electrical connection to an external source such as a fire alarm system.

This standard specifies fire alarm sounders for two types of application environment, type A for indoor use and type B for outdoor use.

A2 This standard is intended to cover voice sounders by the application of additional requirements, tests and performance criteria detailed in Annex C. **A2**

This standard is not intended to cover:

- a) loudspeaker type devices primarily intended for emitting emergency voice messages;
- b) supervisory sounders, for example, within the control and indicating equipment.

2 Normative references

This European Standard incorporates by dated or undated reference, provisions from other publications. These normative references are cited at the appropriate places in the text and the publications are listed hereafter. For dated references, subsequent amendments to or revisions of any of these publications apply to this European Standard only when incorporated in it by amendment or revision. For undated references the latest edition of the publication referred to applies.

<u>Publication</u>	<u>Title</u>
EN 54-1:1996	<i>Fire detection and fire alarm systems — Part 1: Introduction.</i>
EN 50130-4:1995	<i>Alarm systems — Part 4: Electromagnetic compatibility — Product family standard: Immunity requirements for components of fire, intruder and social alarm systems.</i>
EN 60068-1:1994	<i>Environmental testing — Part 1: General and guidance (IEC 60068-1:1988 + Corrigendum 1988 + A1:1992).</i>
EN 60068-2-1:1993	<i>Environmental testing — Part 2: Tests; tests A: cold (IEC 60068-2-1:1990).</i>
EN 60068-2-2:1993	<i>Basic environmental testing procedures — Part 2: Tests; tests B: dry heat (IEC 60068-2-2:1974 + IEC 68-2-2 A:1976).</i>
HD 323.2.3 S2:1987	<i>Basic environmental testing procedures — Part 2: Tests; tests Ca: damp heat, steady state.</i>
EN 60068-2-6:1995	<i>Environmental testing — Part 2: Tests — Tests Fc: Vibration (sinusoidal) (IEC 60068-2-6:1995 + Corrigendum 1995).</i>
EN 60068-2-27:1993	<i>Basic environmental testing procedures — Part 2: Tests — Test Ea and guidance: Shock (IEC 60068-2-27:1987).</i>
IEC 60068-2-30:1980	<i>Basic environmental testing procedures — Part 2: Tests — Test Db and guidance: Damp heat, cyclic (12 + 12-hour cycle).</i>
IEC 60068-2-42:1982	<i>Basic environmental testing procedures — Part 2: Tests — Test Kc: Sulfur dioxide test for contacts and connections.</i>
HD 323.2.56 S1:1990	<i>Basic environmental testing procedures — Part 2: Tests, test Cb: damp heat, steady state, primarily for equipment.</i>
IEC 68-2-63:1997	<i>Environmental testing — Part 2: Test methods — Test Eg: Impact, spring hammer.</i>
EN 60529:1991	<i>Degrees of protection provided by enclosures (IP code) (IEC 60529:1989).</i>
IEC 60651:1979	<i>Sound level meters.</i>
A2 IEC 60695-11-10:1999	<i>Fire hazard testing – Part 11-10: Test flames – 50 W horizontal and vertical flame test methods</i>
IEC 60695-11-20:1999	<i>Fire hazard testing – Part 11-20: Test flames – 500 W flame test methods A2</i>

3 Terms and definitions

For the purposes of this standard, the following terms and definitions and those given in EN 54-1:1996 apply.

3.1 mode (of operation)

one of a possible number of pre-defined sound outputs of the audible alarm device which can be selected by means specified by the manufacturer

3.2 A-weighted sound level

sound pressure, expressed in dB, which is 20 times the logarithm to base ten of the ratio of the A-weighted sound pressure to the reference pressure of 20 mPa (20 mN/m²) - A-weighting characteristics are given in IEC 60651:1979

3.3 type A device

audible fire alarm device - sounder, designed for indoor application

3.4 type B device

audible fire alarm device - sounder, designed for outdoor application

3.5 supervisory sounder

audible device, usually mounted within a piece of equipment (e.g. control and indicating equipment), used for drawing attention, locally, to a change in status or the presence of an abnormal condition indicated by that equipment

3.6 fire alarm sounder

A_2 sound generating device intended to signal an audible warning of fire between a fire detection and fire alarm system and the occupants of a building A_2

4 Requirements

4.1 Compliance

In order to comply with this standard, fire alarm sounders shall meet the requirements of this clause which shall be verified by visual inspection or engineering assessment, shall be tested as described in clause 5 and shall meet the requirements of the tests.

4.2 Sound level

The standard requires that the manufacturer declare sound levels in the data required under 4.6.2. The manufacturer may declare different sound levels for operation under different conditions, for example, when operating on different voltage ranges or with different sound patterns. If this is the case the sound level of each specimen shall be measured under each mode of operation (see 5.3).

When tested in accordance with 5.3. the fire alarm sounder shall produce A-weighted sound levels of at least 65 dB in one direction and not exceeding 120 dB in any direction.

4.3 Frequency and sound pattern

This standard covers sounders which produce different frequencies and sound patterns and, therefore, does not specify a minimum and maximum frequency or a specific sound pattern.

NOTE The sound patterns and frequencies required may vary in different countries. Reference needs to be made to local regulations.

However, the manufacturer shall declare the main sound frequency(ies), frequency range(s) and sound pattern(s) in the data required under 4.6.2.

4.4 Durability

The sounder shall be rated for at least 100 hours operation. No limitation by the manufacturer on duty factor or maximum on-time shall prevent the device from operating the 1 h 'on' 1 h 'off' cycle required by the test procedure described in 5.4.

NOTE This requirement does not apply to the capacity of batteries which may be used within sounders as a means of local storage of operating power. The capacity and charging requirements of such batteries need to meet the requirement of the system.

4.5 Construction

4.5.1 Provision for external conductors

4.5.1.1 The sounder shall provide space within its enclosure for external conductors to be brought in and terminated. Entry holes for conductors or cables shall be provided or the location where such holes are to be made shall be indicated by providing a template or some other suitable means.

4.5.1.2 Terminals for connecting external conductors shall be designed so that the conductors are clamped between metal surfaces without being damaged. Each terminal shall be capable of allowing the connection of any conductor having a cross-sectional area between 0,28 mm² and 1,5 mm² inclusive.

4.5.2 Materials

The sounder shall be constructed of material(s) capable of withstanding the tests described in 5.2 to 5.17. In addition, the material(s) of plastic enclosures shall meet the following flammability requirements:

- a) A_2 IEC 60695-11-10:1999 A_2 Class FV-2 or FH-2 for devices operating from a voltage source less than 30 V r.m.s. or 42,4 V d.c. and consuming less than 15 W of power;
- b) A_2 IEC 60695-11-20:1999 A_2 Class LFV-1 for devices operating from a voltage source greater than 30 V r.m.s. or 42,4 V d.c. and/or consuming more than 15 W of power.

4.5.3 IP ratings

The degree of protection provided by the enclosure of fire alarm sounders shall meet the following requirements:

- a) for Type A audible alarm device - Sounder: Code IP21C of EN 60529:1991;
- b) for Type B audible alarm device - Sounder: Code IP33C of EN 60529:1991.

4.5.4 Access

Means shall be provided to limit access for removal of parts or the whole device and to make adjustment to the mode of operation, e.g. special tool, codes, hidden screws, seals, etc.

4.6 Marking and data

4.6.1 Marking

Each fire alarm sounder shall be clearly marked with the following information:

- a) number of this standard (i.e. EN 54-3);
- b) environment type [i.e. Type A or B (see clause 3)];
- c) name or trademark of the manufacturer or supplier;
- d) manufacturer or supplier model designation (type or number);
- e) terminal designations;
- f) rated supply voltages or voltage ranges (a.c. or d.c.);
- g) power and current consumption;
- h) a mark(s) or code(s) (for example, serial number or batch code), by which the manufacturer can identify, at least, the date or batch and place of manufacture, and the version number(s) of any software contained within the device.

Where any marking on the device uses symbols or abbreviations not in common use then these shall be explained in the data supplied with the device.

The marking need not be discernible when the device is installed and ready for use but shall be visible during installation and shall be accessible during maintenance.

The markings shall not be placed on screws or other easily removable parts.

4.6.2 Data

The information required in 4.6.1 together with the following shall be supplied with the device, or shall be given in a data sheet or technical manual identified on, or with each device:

- a) operating voltage range(s);
- b) supply frequency ranges, where relevant;
- c) for all modes of operation, the minimum A-weighted sound level in dB at a distance of 1 m from the reference point of the device for the following directions of radiation:
 - 1) surface mounted device: at 30° intervals from 15° to 165° through a semi-circular arc in front of the device and centered at the intersection of its normal mounting surface and its principal axis, for two perpendicular planes corresponding to the horizontal and vertical planes of the device in its designed position (see annex A, Figure A2);
 - 2) pole mounted device: at 30° intervals through a 360° circle centered at the intersection of the horizontal plane containing its principal axis and the vertical line through the geometrical centre of the sound diffusing assembly, for two perpendicular planes corresponding to the horizontal and vertical planes of the device in its designed position (see annex A, Figure A3);
- d) main sound frequency(ies), frequency range(s) and sound pattern(s);
- e) IP Code to EN 60529:1991;
- f) any other information necessary to allow correct installation, operation and maintenance of the device.

5 Tests

5.1 General

5.1.1 Atmospheric conditions for tests

Unless otherwise stated in a test procedure, the testing shall be carried out after the test specimen has been allowed to stabilize in the standard atmospheric conditions for testing described in EN 60068-1:1994, as follows:

- a) temperature: 15 °C to 35 °C;
- b) relative humidity: 25 % to 75 %;
- c) air pressure: 86 kPa to 106 kPa.

The temperature and humidity shall be substantially constant for each test where these standard atmospheric conditions are applied.

5.1.2 Operating conditions for tests

If a test method requires a specimen to be sounding, then the specimen shall be connected to suitable power supply equipment as specified in the data provided by the manufacturer. Where, in order to be sounding, a device also requires the application of a control signal or signals, this shall be provided in accordance with the manufacturer's specification.

If a test method requires a specimen to be in the quiescent state, then the specimen shall not be supplied with power unless it is a sounder of the types which have electronic circuits for analyzing control signals and triggering the sound operation, in which case the specimen shall be connected to suitable power supply and control equipment as specified in the data provided by the manufacturer and the control signals shall be arranged so that the specimen is in a non-sounding state.

Unless otherwise specified in the test procedure, the supply parameters applied to the specimen shall be set within the manufacturer's specified range(s) and shall remain constant throughout the tests. The value chosen for each parameter shall be the nominal value, or the mean of the specified range.

If the manufacturer has declared different sound levels for operation under different conditions (see 4.6.2), then, unless otherwise specified by the test procedure, the tests shall be conducted under one selected mode of operation only. Selection of the mode of operation shall be made with the aim to use that which consumes the most power. This will normally be the most continuous or the loudest mode.

NOTE All modes of operation and all voltage ranges are tested in 5.3.

5.1.3 Mounting arrangements

Unless otherwise specified, the specimen shall be mounted by its normal means of attachment in accordance with the manufacturer's instructions on a flat rigid backing board. If these instructions describe more than one method of mounting then the method considered to be most unfavourable shall be chosen for each test.

The detailed mounting arrangements are given in annex A or annex B for the different sound level tests used.

5.1.4 Tolerances

The tolerances for the environmental test parameters shall be given in the basic reference standards for the test (e.g. the relevant part of EN 60068).

If a specific tolerance or deviation limit is not specified in a requirement or test procedure, then a deviation limit of $\pm 5\%$ shall be applied.

5.1.5 Provision for tests

The following shall be provided for testing compliance with this European Standard:

- a) eight specimens of type A or ten specimens of type B sounder with any mounting, bases, boxes or accessories etc.;
- b) any equipment, such as control and indicating equipment, as may be necessary for the correct operation of the device in accordance with the manufacturer's specification;
- c) The data required in 4.6.2.

The specimens submitted shall be deemed representative of the manufacturer's normal production with regard to their construction and settings.

NOTE: The details of the power supply equipment used and/or the equipment used for generating the control signal(s) should be given in the test report.

5.1.6 Test schedule

The specimens shall be tested and inspected according to the schedule given in Table 1.

All the specimen shall be first submitted to the reproducibility test described in 5.2. On completion of the reproducibility test, the specimen with the least loud sound level shall be numbered 1 and the rest arbitrarily numbered from 2 to 8 for Type A or 2 to 10 for Type B.

Unless otherwise required by the test procedure, the mode of operation selected for conducting the reproducibility test shall be used for the other tests.

5.2 Reproducibility

5.2.1 Object of the test

To show that the sound output of the sounder does not vary unduly from specimen to specimen and to establish sound output data for comparison with the sound output measured during and/or after the environmental tests specified in this standard.

5.2.2 Test procedure

The A-weighted sound levels of all the specimens shall be measured as described in annex B.

The measurement shall be recorded in dB for each specimen and the sound level of the loudest and the least loud specimen shall be represented by L_{\max} and L_{\min} respectively.

5.2.3 Test requirements

The audible alarm device shall be deemed to comply with the requirements of this subclause if the difference between L_{\max} and L_{\min} is less than 6 dB.

5.3 Operational performance

5.3.1 Object of the test

To check that the sound levels declared by the manufacturer can be achieved within the specified range(s) of supply parameters (e.g. voltage) and is not unduly dependent on these parameters, and that the maximum A-weighted sound level does not exceed 120 dB at 1 m.

5.3.2 Test procedure

The sound level of the specimen shall be measured in free field conditions using the test method described in annex A with the supply parameters at the maximum and minimum of the specified range(s) [see 4.6.2 a) and b)].

If the manufacturer has declared different sound levels and different operating frequencies for different modes of operation [see 4.6.2 d)], then the sound level of the specimen shall be measured under each mode.

5.3.3 Test requirements

The sounder shall be deemed to comply with the requirements of this subclause if, for each mode of operation:

- a) the A-weighted sound level is greater than 65 dB in at least one direction;
- b) the A-weighted sound level does not exceed 120 dB in any direction;
- c) the sound level measured at each of the specified angles is not less than that declared by the manufacturer [see 4.6.2 c)];
- d) the difference between the A-weighted sound levels measured at the maximum and minimum supply parameters is not more than 6 dB, for each direction measured.

Table 1 — Schedule of tests

Test	Subclause	Specimen No(s)	
		Type A	Type B
Reproducibility	5.2	all	all
Operational performance	5.3	1	1
Durability	5.4	2	2
Dry heat (operational)	5.5	3	3
Dry heat (endurance)	5.6	-	9
Cold (operational)	5.7	3	3
Damp heat, cyclic (operational)	5.8	3	3
Damp heat, steady state (endurance)	5.9	3	3
Damp heat, cyclic (endurance)	5.10	-	10
SO ₂ corrosion (endurance)	5.11	4	4
Shock (operational)	5.12	5	5
Impact (operational)	5.13	6	6
Vibration (operational)	5.14	7	7
Vibration (endurance)	5.15	7	7
Electrostatic discharge (operational)	5.16	8	8
Radiated electromagnetic fields (operational)	5.16	8	8
Conducted disturbances induced by electromagnetic fields (operational)	5.16	8	8
Voltage transients, fast transient bursts (operational)	5.16	8	8
Voltage transients, slow high energy voltage surge (operational)	5.16	8	8
Enclosure protection	5.17	1,2	1,2
<p>1) Where after one of the test specified in 5.5 to 5.16 the A-weighted sound level of the specimen being tested differs from that measured during the reproducibility test by more than 6 dB, a new specimen shall be used for the next test on the schedule for that specimen. The sound level shall be first measured as specified in 5.2.</p> <p>2) The EMC tests specified in 5.16 are not required for sounders which do not rely on active electronic components for their operation.</p> <p>3) The tests on an individual specimen may be carried out in any order except that the reproducibility test (5.2) shall be performed first on all specimens and the tests on specimens 1 and 2 shall be carried out in the order listed (i.e. 5.17 last).</p>			

5.4 Durability

5.4.1 Object of the test

To show that the sound level does not change significantly after prolonged operation of the audible alarm device.

5.4.2 Test procedure

The specimen shall be subjected to the following durability cycle 100 times: the specimen shall be operated for 1 h at the maximum of the supply parameters declared by the manufacturer (see 4.6.2) and then shall be left in the non-operating condition for 1 h. The sound level shall be measured as described in annex B within 1 h of the final period of operation.

5.4.3 Test requirements

The sounder shall be deemed to comply with the requirements of this subclause if the A-weighted sound level measured after 100 durability cycles does not decrease by more than 6 dB from that measured, for the same specimen, under the same operating condition, in the reproducibility test (see 5.2).

5.5 Dry heat (operational)

5.5.1 Object of the test

To demonstrate the ability of the sounder to function correctly at high ambient temperatures, which may occur for short periods in the service environment.

5.5.2 Test procedure

5.5.2.1 Reference

The test apparatus and procedure shall be as described in test Bb for non-heat dissipating specimens or test Bd for heat dissipating specimens as described in EN 60068-2-2:1993 except that the test shall be conducted in a reverberation chamber as described in annex B.

5.5.2.2 State of specimen during conditioning

The specimen shall be mounted in a reverberation test chamber as described in annex B. The specimen shall be maintained in the quiescent state during the conditioning period except during the last hour when it shall be sounding (see 5.1.2).

5.5.2.3 Conditioning

The air temperature in the reverberation test chamber shall be increased to the test temperature at a rate not exceeding 1 °C/min. The test conditions in Table 2 shall be applied.

Table 2 — Conditions for dry heat (operational) test

Type	Temperature °C	Duration h
A	55 ± 2	16
B	70 ± 2	16

5.5.2.4 Measurements during conditioning

- Except during the final 15 min of conditioning, those devices requiring power during the quiescent state (see 5.1.2) shall be monitored for false operation and fault signals during the conditioning period.
- The sound level shall be measured as described in annex B during the final 15 min of the conditioning.

5.5.2.5 Final measurements

The sound level of the specimen shall be measured as described in annex B after the recovery period specified in EN 60068-2-2:1993.

5.5.3 Test requirements

The sounder shall be deemed to comply with the requirements of this subclause if no false operation or fault signals have been detected during the conditioning period [see 5.5.2.4.a)] and the mean A-weighted sound levels measured during the conditioning period [see 5.5.2.4.b)] and after the recovery period (see 5.5.2.5) do not decrease by more than 6 dB from that measured for the same specimen in the reproducibility test (see 5.2).

NOTE: If the fire alarm device is combined with a heat detector which could operate at $(55 \pm 2) ^\circ\text{C}$, then the response of the heat detector may be disabled or ignored during the test.

5.6 Dry heat (endurance)

5.6.1 Object of the test

To demonstrate the ability of the sounder to withstand long-term ageing effects.

5.6.2 Test procedure

5.6.2.1 Reference

The test apparatus and procedure shall be as described in test Ba or Bb of EN 60068-2-2:1993, including amendments A1:1993 and A2:1994.

5.6.2.2 State of the specimen during conditioning

The specimen shall not be supplied with power during the conditioning.

5.6.2.3 Conditioning

The test conditions in Table 3 shall be applied.

Table 3 — Conditions for dry heat (endurance) test

Type	Temperature $^\circ\text{C}$	Duration days
A	No test	No test
B	70 ± 2	21

5.6.2.4 Measurements during conditioning

No measurements are required during the conditioning.

5.6.2.5 Final measurements

The sound level of the specimen shall be measured as described in annex B after the recovery period specified in EN 60068-2-2:1993.

5.6.3 Test requirements

The sounder shall be deemed to comply with the requirements of this subclause if the mean A-weighted sound level measured after the recovery period (see 5.6.2.5) does not decrease by more than 6 dB from that measured for the same specimen in the reproducibility test (see 5.2).

5.7 Cold (operational)

5.7.1 Object of the test

To demonstrate the ability of the sounder to function correctly at low ambient temperatures appropriate to the anticipated service environment.

5.7.2 Test procedure

5.7.2.1 Reference

The test procedure shall be as described in test Ab for non-dissipating specimens, or test Ad for heat dissipating specimens, of EN 60068-2-1:1993 except that the test shall be conducted in a reverberation chamber as described in annex B.

5.7.2.2 State of specimen during conditioning

The specimen shall be mounted in a reverberation test chamber as described in annex B. The specimen shall be maintained in the quiescent state during the conditioning period except during the last hour when it shall be sounding (see 5.1.2).

5.7.2.3 Conditioning

The air temperature in the reverberation test chamber shall be reduced to the required test temperature at a rate not exceeding $1 ^\circ\text{C}/\text{min}$. The test conditions in Table 4 shall be applied.

Table 4 — Conditions for cold (operational) test

Type	Temperature °C	Duration h
A	-10 ± 3	16
B	-25 ± 3	16

NOTE: In countries with very cold outside temperatures a test temperature of -40 ± 3 °C should be used for type B.

5.7.2.4 Measurements during conditioning

- a) Except as described in 5.8.2.4.b), sounders which require power during the quiescent state (see 5.1.2) shall be monitored for false operation and fault signals during the conditioning period.
- b) The sound level shall be measured as described in annex B during the final 15 min of the conditioning.

5.7.2.5 Final measurements

The sound level of the specimen shall be measured as described in annex B after the recovery period specified in EN 60068-2-1:1993.

5.7.3 Test requirements

The sounder shall be deemed to comply with the requirements of this subclause if no false operation or fault signals have been detected during the conditioning period [see 5.7.2.4.a)] and the mean A-weighted sound levels measured during the conditioning period [see 5.7.2.4.b)] and after the recovery period (see 5.7.2.5) do not decrease by more than 6 dB from that measured for the same specimen in the reproducibility test (see 5.2).

5.8 Damp heat, cyclic (operational)

5.8.1 Object of the test

To demonstrate the immunity of the sounder to an environment with high relative humidity, where condensation may occur on the device.

5.8.2 Test procedure

5.8.2.1 Reference

The test apparatus and procedure shall be as described in IEC 60068-2-30:1980, including amendment A1:1985, using the Variant 1 test cycle and controlled recovery conditions.

5.8.2.2 State of the specimen during conditioning

The specimen shall be maintained in the quiescent state during the conditioning period except during the last half hour of the high temperature phase of the last cycle when it shall be sounding (see 5.1.2).

5.8.2.3 Conditioning

The test conditions in Table 5 shall be applied.

Table 5 — Conditions for Damp heat, cyclic (operational) test

Type	Lower temperature °C	Relative humidity (lower temperature) %	Upper temperature °C	Relative humidity (upper temperature) %	Number of cycles
A	25 ± 3	> 95	40 ± 2	93 ± 3	2
B	25 ± 3	> 95	55 ± 2	93 ± 3	2

5.8.2.4 Measurements during conditioning

- a) Except during the final 30 min of conditioning, those devices requiring power during the quiescent state (see 5.1.2) shall be monitored for false operation and fault signals during the conditioning period.
- b) The specimen shall be checked for audible operation during the final half hour of the high temperature phase in the last cycle.

5.8.2.5 *Final measurements*

The sound level of the specimen shall be measured as described in annex B after the recovery period specified in IEC 60068-2-30:1980.

5.8.3 *Test requirements*

The sounder shall be deemed to comply with the requirements of this subclause if no false operation or fault signals are detected [see 5.8.2.4.a)] and the specimen operates correctly [see 5.8.2.4.b)] during the conditioning period, and if the mean A-weighted sound level measured after the recovery period (see 5.8.2.5) does not decrease by more than 6 dB from that measured for the same specimen in the reproducibility test (see 5.2).

5.9 **Damp heat, steady state (endurance)**

5.9.1 *Object of the test*

To demonstrate the ability of the sounder to withstand the long-term effects of humidity in the service environment (e.g. changes in electrical properties due to absorption, chemical reactions involving moisture, galvanic corrosion, etc.).

5.9.2 *Test procedure*

5.9.2.1 *Reference*

The test apparatus and procedure shall be as described in test Cb of HD 323.2.56 S1:1990 or in test Ca of HD 323.2.3 S2:1987, including amendment A1:1984, if the use of HD 323.2.56 S1:1990 is impractical.

5.9.2.2 *State of the specimen during conditioning*

The specimen shall not be supplied with power during the conditioning.

5.9.2.3 *Conditioning*

The test conditions in Table 6 shall be applied.

Table 6 — Conditions for Damp heat, steady state (endurance) test

Type	Temperature °C	Relative humidity %	Duration days
A	40 ± 2	93 ± 3	21
B	40 ± 2	93 ± 3	21

5.9.2.4 *Measurements during conditioning*

No measurements are required during the conditioning.

5.9.2.5 *Final measurements*

The sound level of the specimen shall be measured as described in annex B after the recovery period specified in HD 323.2.56 S1:1990 or HD 323.2.3 S2:1987.

5.9.3 *Test requirements*

The sounder shall be deemed to comply with the requirements of this subclause if the mean A-weighted sound level measured after the recovery period (see 5.9.2.5) does not decrease by more than 6 dB from that measured for the same specimen in the reproducibility test (see 5.2).

5.10 **Damp heat, cyclic (endurance)**

5.10.1 *Object of the test*

To demonstrate the ability of the sounder to withstand the longer-term effects of high humidity and condensation.

5.10.2 *Test procedure*

5.10.2.1 *Reference*

The test apparatus and procedure shall be as described in IEC 60068-2-30:1980, including amendment A1:1985, using the Variant 1 test cycle and controlled recovery conditions.

5.10.2.2 *State of the specimen during conditioning*

The specimen shall not be supplied with power during the conditioning.

5.10.2.3 *Conditioning*

The test conditions in Table 7 shall be applied.

Table 7 — Conditions for Damp heat, cyclic (endurance) test

Type	Temperature °C	Number of cycles
A	No test	No test
B	55 ± 2	6

5.10.2.4 *Measurements during conditioning*

No measurements are required during the conditioning.

5.10.2.5 *Final measurements*

The sound level of the specimen shall be measured as described in annex B after the recovery period specified in IEC 60068-2-30:1980.

5.10.3 *Test requirements*

The sounder shall be deemed to comply with the requirements of this subclause if the mean A-weighted sound level measured after the recovery period (see 5.10.2.5) does not decrease by more than 6 dB from that measured for the same specimen in the reproducibility test (see 5.2).

5.11 **Sulfur dioxide (SO₂) corrosion (endurance)**

5.11.1 *Object of the test*

To demonstrate the ability of the sounder to withstand the corrosive effect of sulfur dioxide as an atmospheric pollutant.

5.11.2 *Test procedure*

5.11.2.1 *Reference*

The test apparatus and procedure shall be as described in IEC 60068-2-42:1982, except for the relative humidity of the test atmosphere, which shall be maintained at (93 ± 3) % instead of (75 ± 5) %.

5.11.2.2 *State of the specimen during conditioning*

The specimen shall have untinned copper wires, of appropriate diameter, connected to sufficient terminals to allow the functional test to be made after conditioning, without making further connections to the specimen.

The specimen shall not be supplied with power during the conditioning.

5.11.2.3 *Conditioning*

The test conditions in Table 8 shall be applied.

Table 8 — Conditions for Sulfur dioxide (SO₂) corrosion (endurance) test

Type	Sulfur dioxide content ppm	Temperature °C	Relative humidity %	Duration days
A	25 ± 5	25 ± 2	93 ± 3	21
B	25 ± 5	25 ± 2	93 ± 3	21

NOTE ppm = parts per million by volume

5.11.2.4 *Measurements during the conditioning*

No measurements are required during the conditioning.

5.11.2.5 *Final measurements*

Immediately after the conditioning the specimen shall be subjected to a drying period of 16 hours at (40 ± 2) °C, and relative humidity 50 %, followed by a recovery period of 1 to 2 hours at the standard laboratory conditions.

The sound level of the specimen shall be measured as described in annex B after the specified recovery period.

5.11.3 *Test requirements*

The sounder shall be deemed to comply with the requirements of this subclause if the mean A-weighted sound level measured after the recovery period (see 5.11.2.5) does not decrease by more than 6 dB from that measured for the same specimen in the reproducibility test (see 5.2).

5.12 Shock (operational)

5.12.1 *Object of the test*

To demonstrate the immunity of the sounder to mechanical shocks, which are likely to occur, albeit infrequently, in the anticipated service environment.

5.12.2 *Test procedure*

5.12.2.1 *Reference*

The test apparatus and procedure shall be as described in test Ea of EN 60068-2-27:1993, except that the conditioning shall be as described in 5.12.2.3.

5.12.2.2 *State of the specimen during conditioning*

The specimen shall be mounted on a rigid fixture and shall be maintained in the quiescent state during the conditioning period (see 5.1.2).

5.12.2.3 *Conditioning*

The test conditions in Table 9 shall be applied.

Table 9 — Conditions for Shock (operational) test

Sounder type	Pulse type	Pulse duration (ms)	Maximum acceleration related to specimen mass M in kg m s^{-2}		Number of shock directions	Number of pulses per direction
			$M \leq 4,75$ kg	$M > 4,75$ kg		
A	Half sine	6	$10 \times (100 - 20M)$	No test	6	3
B	Half sine	6	$10 \times (100 - 20M)$	No test	6	3

5.12.2.4 *Measurements during conditioning*

The specimen shall be monitored for false operation and fault signals during the conditioning period and a further 2 min after the end of the conditioning period.

5.12.2.5 *Final measurements*

The sound level of the specimen shall be measured as described in annex B after the conditioning.

5.12.3 *Test requirements*

The sounder shall be deemed to comply with the requirements of this subclause if no false operation or fault signals are detected (see 5.12.2.4) during the conditioning period and the mean A-weighted sound level measured after the conditioning period (see 5.12.2.5) does not decrease by more than 6 dB from that measured for the same specimen in the reproducibility test (see 5.2).

5.13 Impact (operational)

5.13.1 Object of the test

To demonstrate the immunity of the sounder to mechanical impacts upon its surface, which it may sustain in the normal service environment, and which it can reasonably be expected to withstand.

5.13.2 Test procedure

5.13.2.1 Apparatus

The test apparatus shall be as described in test Eg of IEC 68-2-63:1997.

5.13.2.2 State of the specimen during conditioning

The specimen shall be maintained in the quiescent state during the conditioning period (see 5.1.2).

5.13.2.3 Conditioning

Impact shall be applied to each accessible surface of the specimen at any point(s) considered likely to suffer damage or to impair the operation of the specimen.

The test conditions in Table 10 shall be applied.

Table 10 — Conditions for Impact (operational) test

Type	Impact energy J	Number of impacts per accessible point
A	0,5 ± 0,04	3
B	0,5 ± 0,04	3

5.13.2.4 Measurement during conditioning

The specimen shall be monitored for false operation and fault signals during the conditioning period and a further 2 min after the end of the conditioning period.

5.13.2.5 Final measurements

The sound level of the specimen shall be measured as described in annex B after the conditioning.

5.13.3 Test requirements

The sounder shall be deemed to comply with the requirements of this subclause if no false operation or fault signals are detected (see 5.13.2.4) during the conditioning period and the mean A-weighted sound level measured after the conditioning period (see 5.13.2.5) does not decrease by more than 6 dB from that measured for the same specimen in the reproducibility test (see 5.2).

5.14 Vibration, sinusoidal (operational)

5.14.1 Object of the test

To demonstrate the immunity of the sounder to vibration at levels considered appropriate to the normal service environment.

5.14.2 Test procedure

5.14.2.1 Reference

The test apparatus and procedure shall be as described in test Fc of EN 60068-2-6:1995.

5.14.2.2 State of the specimen during conditioning

The specimen shall be mounted on a rigid structure and the vibration shall be applied in each of three mutually perpendicular axes, in turn. The specimen shall be mounted so that one of the three axes is perpendicular to its normal mounting plane.

The conditioning shall be applied to the specimen in both the quiescent state and when sounding (see 5.1.2).

5.14.2.3 Conditioning

The test conditions in Table 11 shall be applied.

Table 11 — Conditions for Vibration, sinusoidal (operational) test

Type	Frequency range Hz	Acceleration amplitude $\text{m s}^{-2} \{g_n\}$	Number of axis	Sweep rate octave/min	Number of sweep cycles per axis per functional conditions (see 5.14.2.2)
A	10 to 150	5 {0,5}	3	1	2
B	10 to 150	5 {0,5}	3	1	2

NOTE The vibration operational and endurance tests may be combined such that the specimen is subjected to the operational test conditioning followed by the endurance test conditioning in one axis before changing to the next axis. Only one final measurement need then be made.

5.14.2.4 Measurements during conditioning

The specimen shall be monitored during the conditioning period to detect:

- a) any false operation or fault signals when in the quiescent state; and
- b) any interruption of sound output when sounding.

5.14.2.5 Final measurements

The sound level of the specimen shall be measured as described in annex B after the conditioning.

5.14.3 Test requirements

The sounder shall be deemed to comply with the requirements of this subclause if no false operation or fault signals and no interruption of sound output are detected when sounding during the conditioning period (see 5.14.2.4) and if the mean A-weighted sound level measured after the conditioning period (see 5.14.2.5) does not decrease by more than 6 dB from that measured for the same specimen in the reproducibility test (see 5.2).

5.15 Vibration, sinusoidal (endurance)

5.15.1 Object of the test

To demonstrate the ability of the audible alarm device to withstand the long-term effects of vibration at levels appropriate to the service environment.

5.15.2 Test procedure

5.15.2.1 Reference

The test apparatus and procedure shall be as described in test Fc of EN 60068-2-6:1995.

5.15.2.2 State of the specimen during conditioning

The specimen shall be mounted on a rigid fixture and the vibration shall be applied in each of three mutually perpendicular axes, in turn. The specimen shall be mounted so that one of the three axes is perpendicular to its normal mounting axis.

The specimen shall not be supplied with power during the conditioning.

5.15.2.3 Conditioning

The test conditions in Table 12 shall be applied.

Table 12 — Conditions for Vibration, sinusoidal (endurance) test

Type	Frequency range Hz	Acceleration amplitude $\text{m s}^{-2} \{g_n\}$	Number of axis	Sweep rate octave/min	Number of sweep cycles per axis (see 5.14.2.2)
A	10 to 150	10 {1}	3	1	20
B	10 to 150	10 {1}	3	1	20

NOTE The vibration operational and endurance tests may be combined such that the specimen is subjected to the operational test conditioning followed by the endurance test conditioning in one axis before changing to the next axis. Only one final measurement need then be made.

5.15.2.4 *Measurements during conditioning*

No measurements are required during the conditioning.

5.15.2.5 *Final measurements*

The sound level of the specimen shall be measured as described in annex B immediately after the conditioning.

5.15.3 *Test requirements*

The sounder shall be deemed to comply with the requirements of this subclause if the mean A-weighted sound level measured after the conditioning period (see 5.15.2.5) does not decrease by more than 6 dB from that measured for the same specimen in the reproducibility test (see 5.2).

5.16 **Electromagnetic compatibility (EMC), immunity (operational)**

5.16.1 *Object of the tests*

To demonstrate the immunity of the sounder to electrostatic discharges, electromagnetic fields and fast low energy and slow high energy transients.

5.16.2 *Test procedures*

5.16.2.1 *Reference*

EMC, immunity tests shall be carried out as described in EN 50130-4:1995. The following tests shall be conducted:

- a) electrostatic discharge;
- b) radiated electromagnetic fields;
- c) conducted disturbances induced by electromagnetic fields;
- d) fast transient burst;
- e) slow high energy voltage surges.

5.16.2.2 *State of the specimen during conditioning*

- a) For tests a), d) and e) in 5.16.2.1, the conditioning shall be applied to the specimen only in the quiescent state.
- b) For tests b) and c) in 5.16.2.1, the conditioning shall be applied to the specimen in both the quiescent state and when sounding.

5.16.2.3 *Conditioning*

The tests conditions specified in EN 50130-4:1995 for the tests listed in 5.16.2.1 shall be applied.

5.16.2.4 *Measurements during conditioning*

During the conditioning period, the specimen shall be monitored to detect:

- a) any false operation or fault signals when in the quiescent state; and
- b) any interruption of sound output when sounding.

5.16.2.5 *Final measurements*

The sound level of the specimen shall be measured as described in annex B after the conditioning.

5.16.3 *Test requirements*

For these tests the criteria for compliance specified in EN 50130-4:1995 and the following shall apply:

- a) no false operation or fault signals and, when sounding, no interruption of sound output are detected during the conditioning period (see 5.16.2.4); and
- b) the mean A-weighted sound level measured after the conditioning period (see 5.16.2.5) does not decrease by more than 6 dB from that measured for the same specimen in the reproducibility test (see 5.2).

5.17 **Enclosure protection**

5.17.1 *Object of the tests*

To demonstrate that the degree of protection provided by the enclosure of the fire alarm sounder, with regard to the ingress of solid foreign objects and the harmful effects due to the ingress of water, meets the minimum requirements of this European Standard (see 4.5.3).

5.17.2 *Definition of “enclosure”*

The enclosure of the fire alarm sounder shall be taken as comprising any parts of the outer physical envelope of the device which prevent or restrict access of solid foreign objects to the sound transducer, electronic assembly(ies) and wiring terminals.

NOTE Ingress of liquid inside the enclosure may be possible, but should not adversely affect the operation of the device.

5.17.3 *Test procedures*

5.17.3.1 *Reference*

The test apparatus and procedures shall be as described in EN 60529:1991. The following tests shall be conducted:

- a) protection against solid foreign objects indicated by the first characteristic numeral;
- b) protection against access to hazardous parts indicated by the additional letter;
- c) protection against water indicated by the second characteristic numeral.

5.17.3.2 *State of the specimen during conditioning*

The specimen under test shall be:

- a) unpowered during the test for protection against solid foreign objects;
- b) unpowered during the test for protection against access to hazardous parts;
- c) powered and sounding during the test for protection against water.

The specimen under test shall be mounted as specified in EN 60529:1991 and shall include all wiring termination boxes which form part of the fire alarm sounder when installed.

5.17.3.3 *Conditioning*

The test conditions specified in EN 60529:1991 shall be applied for the following IP Codes:

- a) Type A, indoor use: IP21C;
- b) Type B, outdoor use: IP33C.

5.17.3.4 *Measurements during conditioning*

During the conditioning for the test for protection against water, the specimen shall be monitored to check that the sounder continues to sound, in the selected mode of operation, without interruptions.

5.17.3.5 *Final measurements*

At the end of the conditioning period for the test for protection against water:

- a) the sound level of the specimen shall be measured as described in annex B;
- b) the specimen shall be examined for ingress of water inside the enclosure.

5.17.4 Test requirements

The sounder shall be deemed to comply with the requirements of this subclause if:

- a) the specimen tested complies with the acceptance conditions for the test for protection against solid foreign objects of EN 60529:1991, subclause 13.3;
- b) the specimen tested complies with the acceptance conditions for the test against protection against access to hazardous parts of EN 60529:1991, subclause 15.3;
- c) after the conditioning period for the test for protection against water (see 5.17.3.5):
 - 1) the mean A-weighted sound level measured does not decrease by more than 6 dB from that measured for the same specimen in the reproducibility test (see 5.2); and
 - 2) no water has penetrated the enclosure or, if water has penetrated the enclosure, the device incorporates adequate provision for drainage.

Annex A (normative)

Sound level test for fire alarm sounders

A.1 General

The specimen to be tested shall be mounted as described in A.2 and placed in a free field or simulated free field condition.

Measurement conditions in which the sound pressure varies with the distance from a point according to a $1/r^2$ law within tolerances of $\pm 10\%$ (± 1 dB for the sound pressure level), at the positions that will be occupied by the device and the microphone during the measurements, are considered to be satisfactory.

A.2 Mounting arrangements

A.2.1 The manufacturer's normal mounting conditions shall be simulated.

A.2.2 For surface mounted devices, the specimen shall be rigidly mounted on a smooth flat block with free material all around it at least 4 times the height h of the device above the mounting block (see Figure A1). The mounting block shall be of sufficient mass to resist the inertial effect of the specimen tested and shall have a coefficient of absorption better than 0,06.

NOTE A suitable mounting arrangement is shown in Figure A1.

A.2.3 For pole mounted devices, the specimen shall be mounted by its normal means to a suitable rigid structure with sufficient mass to resist the inertial effect of the specimen to be tested. Care shall be taken to ensure that the mounting structure does not obstruct the measurement field.

A.3 Instrumentation

A sound level meter conforming to IEC 60651:1979 Class 2 or better shall be used.

A.4 Background noise level

Measurement shall be deemed valid if, at the microphone positions, the background A-weighted sound level is at least 10 dB below the nominal A-weighted sound level of the device under test.

A.5 Measurement of sound level

A.5.1 A-weighted sound level shall be measured and recorded in dB using the F (Fast) detector indicator characteristic. In the case of fluctuating sound, the maximum value indicated during at least a complete cycle of the sound pattern shall be taken.

A.5.2 One value of sound level shall be taken at a radius of 3 m from the reference point of the device for each of the following microphone positions:

- a) surface mounted device: at 30° intervals from 15° to 165° through a semi-circular arc centered at the reference point of the device for two perpendicular planes corresponding to the horizontal and vertical planes of the device in its designed position (see Figure A2);
- b) pole mounted device: at 30° intervals through a 360° circle centered at the reference point of the device, for two perpendicular planes corresponding to the horizontal and vertical planes of the device in its designed position (see Figure A3).

A.5.3 The A-weighted sound level at 1 m shall be derived by adding a conversion factor of 9,54 dB to the value obtained at 3 m.

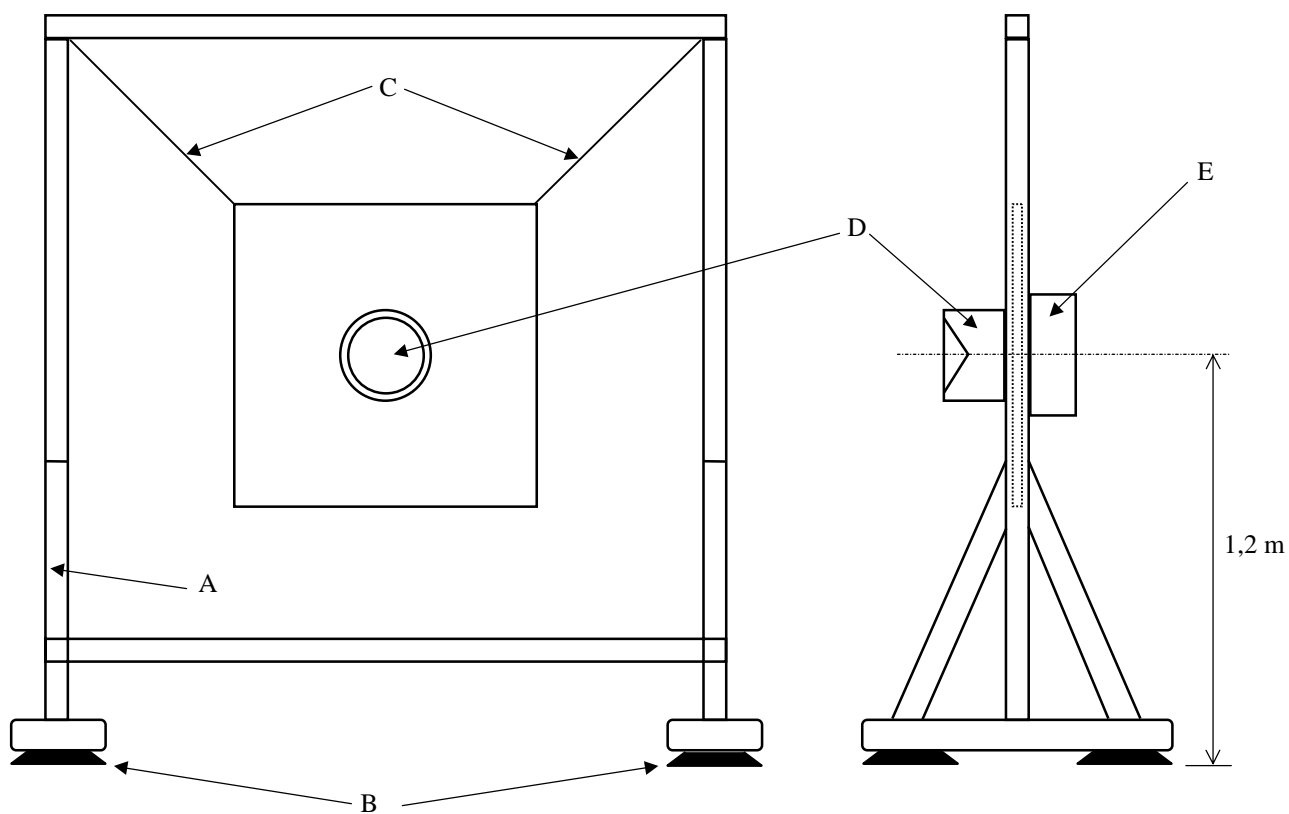

key

- A Timber construction suitable for load
- B Shock pads to minimize vibration transmission
- C Suspension wires
- D Alarm device - sounder
- E Balancing mass

NOTE If the nature of the ground or floor is found to influence the results obtained, it will be necessary to place sound absorbent material on the ground (or floor) for a distance of at least 3 m from the projection of the reference point.

Figure A1 — Suggested method of mounting

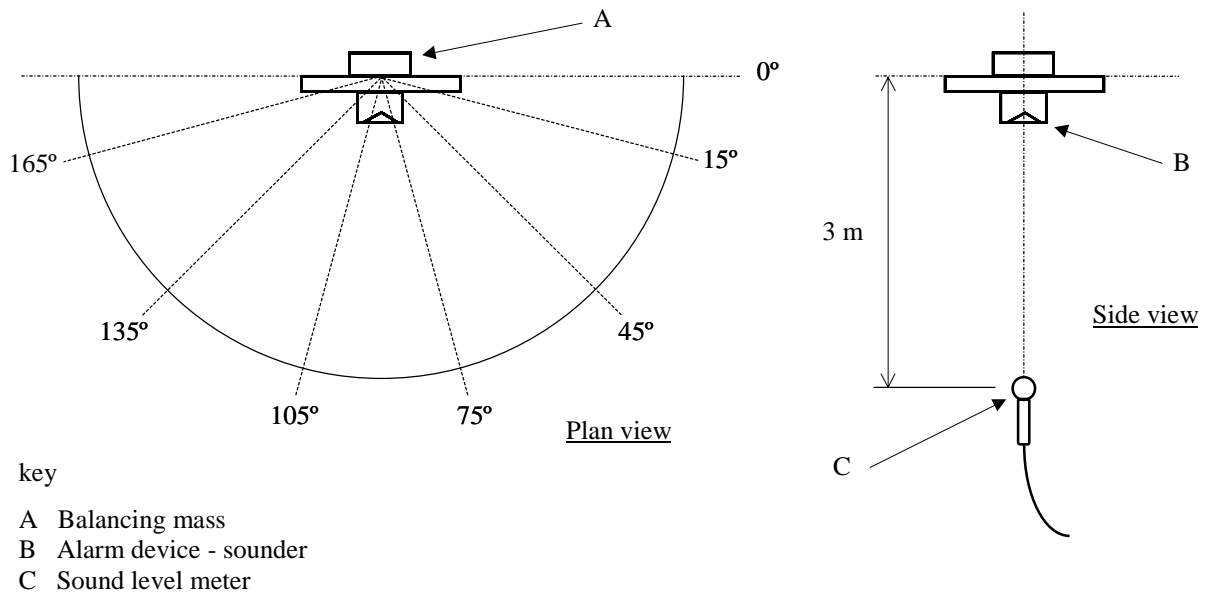

NOTE Alarm device may be rotated 90° to carry out measurements in the vertical plane.

Figure A2 — Measurement positions — Surface mounted devices

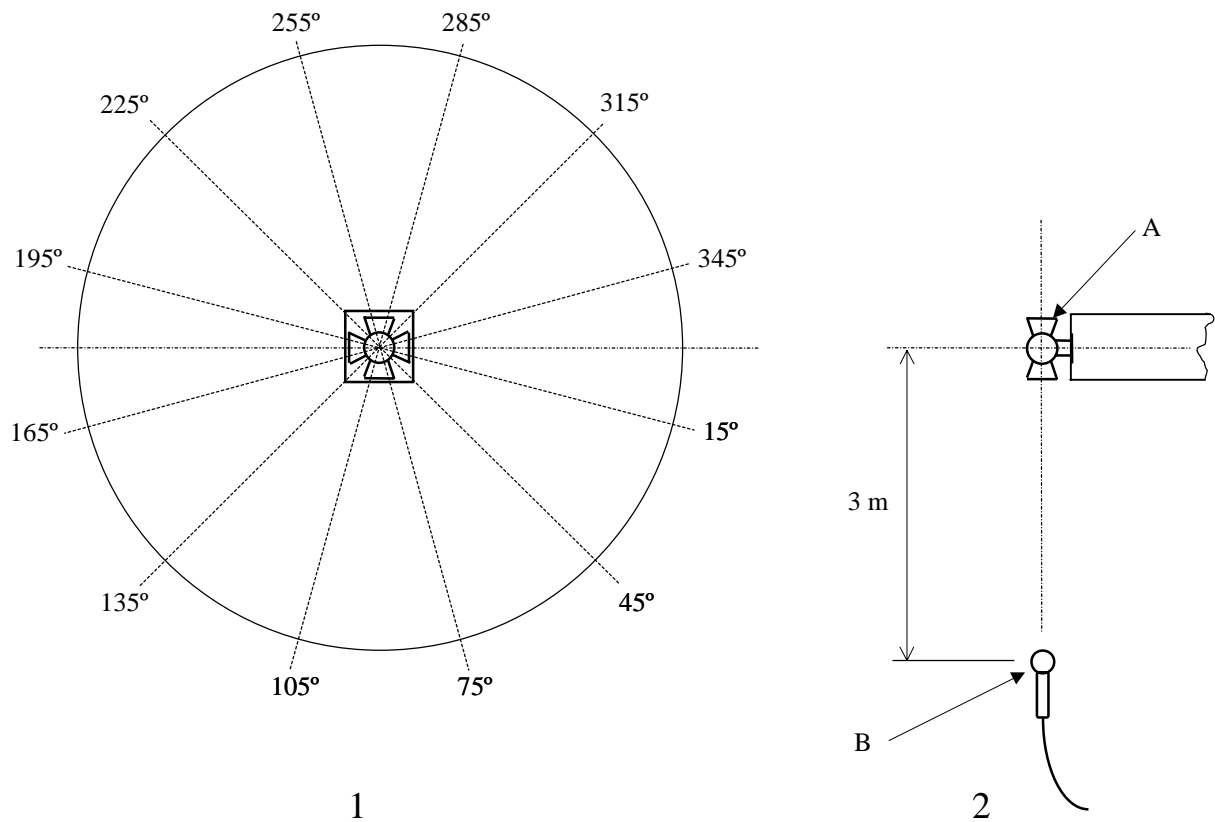

Figure A3 — Measurement positions — Pole mounted devices

Annex B (normative)

Comparative sound level test during environmental conditioning

B.1 General

B.1.1 The test chamber and sound level measurement method described are for carrying out comparative assessment of the performance of fire alarm sounders before, during and following the environmental conditioning specified in this standard.

B.1.2 The specimen to be tested shall be placed in a reverberation test chamber as described in B.2 which shall have a sufficiently uniform repartition of sound energy throughout its volume to ensure consistent reading of sound pressure for differing environmental conditioning.

NOTE As the test method is concerned with establishing comparative test results on a single device, some of the parameters which would apply to the design of reverberation chambers for precision measurement have been relaxed.

The same test chamber construction and the same mounting conditions shall be used for all tests carried out on a given specimen and these shall be fully described in the test report.

B.2 Test chamber

B.2.1 Size

The volume of the test chamber expressed in m^3 shall not be less than 0,5 or $125 \times 10^6 / f^3$ where 90 % of the sound power is at frequencies above f , whichever is greater.

The specimen to be tested shall not exceed 5 % of the volume of the test chamber.

B.2.2 Shape

The test chamber shall have six walls and shall be constructed so that either:

- a) no surfaces are parallel, the angles between each surface are such as to minimize the resonant mode and the maximum length, width and height are the same; or
- b) it is rectangular and the ratio of the length of each side, y/x and z/x conforms to the value in Table B.1.

Table B.1 — Ratios of lengths

y/x	z/x
0,83	0,47
0,83	0,65
0,79	0,63

NOTE Examples of suitable test chambers of the type described in B.2.2 a) and B.2.2 b) are shown in Figure B1 and Figure B2 respectively.

B.2.3 Rigidity

The materials used, the thickness of each wall and the way the walls are joined shall be adequate to minimize measuring uncertainties caused by induced vibrations.

For example, a chamber constructed of marine plywood with a minimum thickness in mm of 25 or $25 V^{1/3}$ (where V is the volume of the chamber in m^3) whichever is greater, and with walls joined together using a recognized carpentry joint supplemented by a suitable waterproof adhesive and screws is suitable.

Where removable panels are provided to permit the mounting of the specimen under test and other measuring equipment, these shall be of the same material and thickness as the rest of the chamber and be secured in place along the perimeter of the aperture at intervals not greater than 100 mm.

B.2.4 *Surface treatment*

The inner surface of each side of the chamber shall be equally reflective with an average absorption coefficient not exceeding 0,06 within the frequency band of interest. For example, the use of a Formica laminate bonded to plywood walls is suitable.

B.3 **Mounting arrangements**

The specimen to be tested shall be rigidly mounted by its normal means to the centre of one of the walls of the chamber.

B.4 **Instrumentation**

The basic instrumentation shall consist of a rotating microphone, an amplifier with A-weighting network, a squaring and averaging circuit and an indicating device. A sound level meter conforming to IEC 60651:1979 Class 2 or better is suitable.

NOTE If, at extremes of environmental conditioning, e.g. temperature or humidity, the sensitivity of the complete instrument including the microphone is outside the specified value for the type of equipment used, it will be necessary to take into account the correction information provided by the manufacturer of the instrument.

B.5 **Background noise level**

Measurements are deemed valid if, at the microphone positions, the background A-weighted sound level is at least 10 dB below the nominal A-weighted sound level of the device under test.

B.6 **Test procedure**

B.6.1 *Number and positioning of microphones*

In order to reduce the effect of non-uniformity within the chamber, measurements shall be made with a rotating microphone over a circumference having a diameter of not less than 300 mm.

The microphone traverse shall not lie in any plane within 10° of a surface of the chamber. No point on the traverse shall be closer than $\lambda/4$, where λ is the wavelength of the lowest frequency range of interest, to any wall of the chamber.

The minimum distance in m between any microphone position and the specimen under test shall not be less than $0.3 V^{1/3}$ where V is the volume of the test chamber in m^3 .

The same microphone arrangement shall be used for all the tests carried out on a given specimen and this shall be fully described in the test report.

NOTE Care should be exercised in mounting the microphone to eliminate interferences from connecting cables and from vibrations that may be induced by the test chamber and/or the rotating mechanism.

B.6.2 *Measurement of sound level*

The sound level shall be measured by averaging the A-weighted sound pressure level for a whole number of revolutions of the microphone, either in a continuous sweep or at, at least, eight evenly distributed positions per revolution.

If the measurement is made in a continuous sweep, then the measuring path shall be traversed by the microphone at a constant speed, such that a single period of the microphone traverse shall not be less than 60 s or 60 times the repetition rate of any sound pattern produced by the specimen under test, whichever is the greater.

If the measurement is made at, at least, eight evenly distributed positions, the maximum A-weighted sound pressure level shall be measured at each point using the F (Fast) detector indicator characteristic. The measurement at each point shall be made for a period of $(60/n)$ s (where n is the number of points) or for at least a complete cycle of the sound pattern, whichever is the greater.

NOTE:
$$\overline{\text{dB}} = 10 \log \frac{1}{n} \left(\text{anti log} \frac{\text{dB}_1}{10} + \text{anti log} \frac{\text{dB}_2}{10} + \dots \dots \text{anti log} \frac{\text{dB}_n}{10} \right)$$

where: $\overline{\text{dB}}$ = the average sound pressure level;
 $\text{dB}_1, \text{dB}_2, \dots, \text{dB}_n$ = the individual sound pressure levels;
 n = the number of individual sound pressure levels to be averaged.

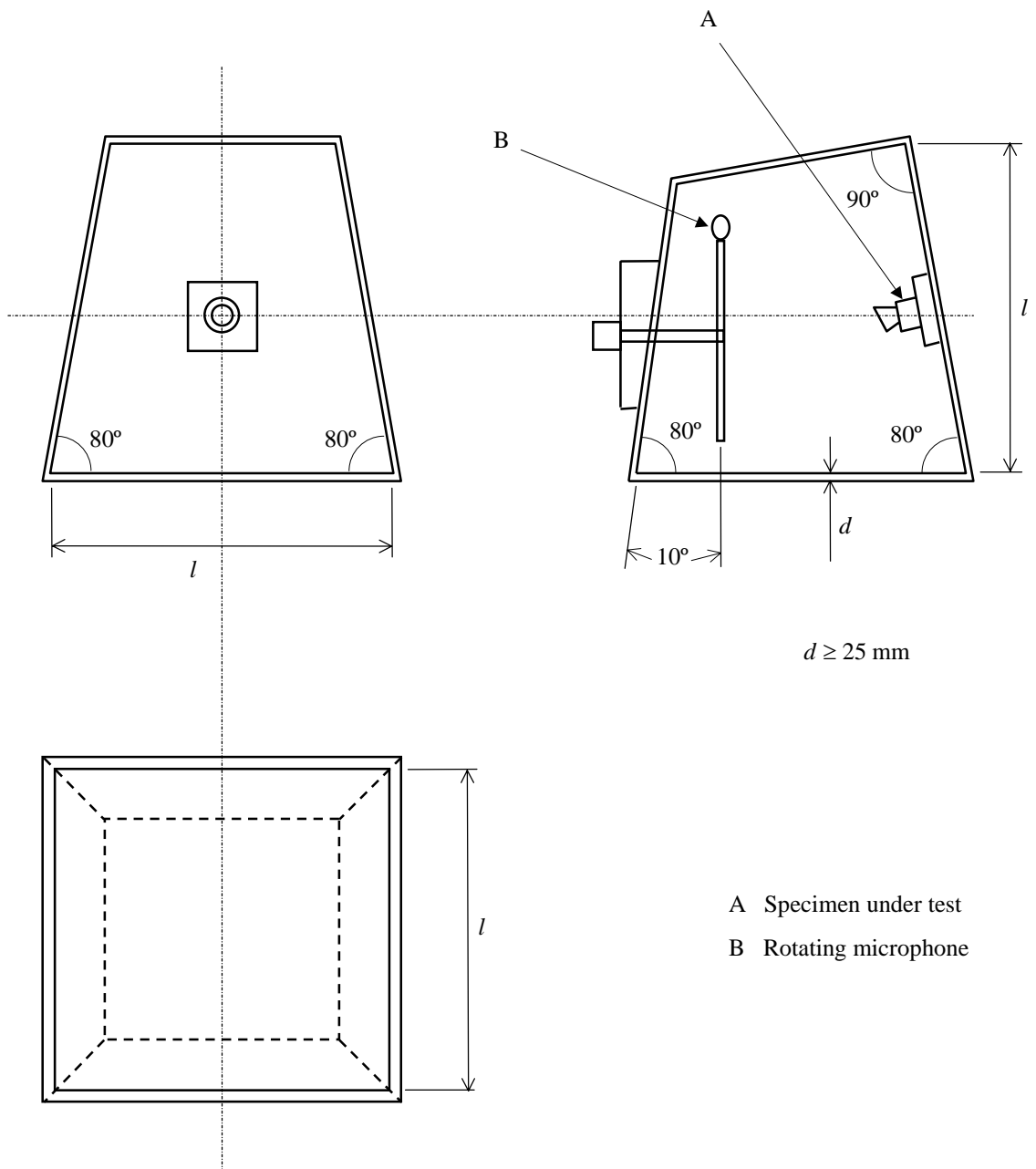

Figure B1 — Example of reverberation chamber as described in B.2.2 a)

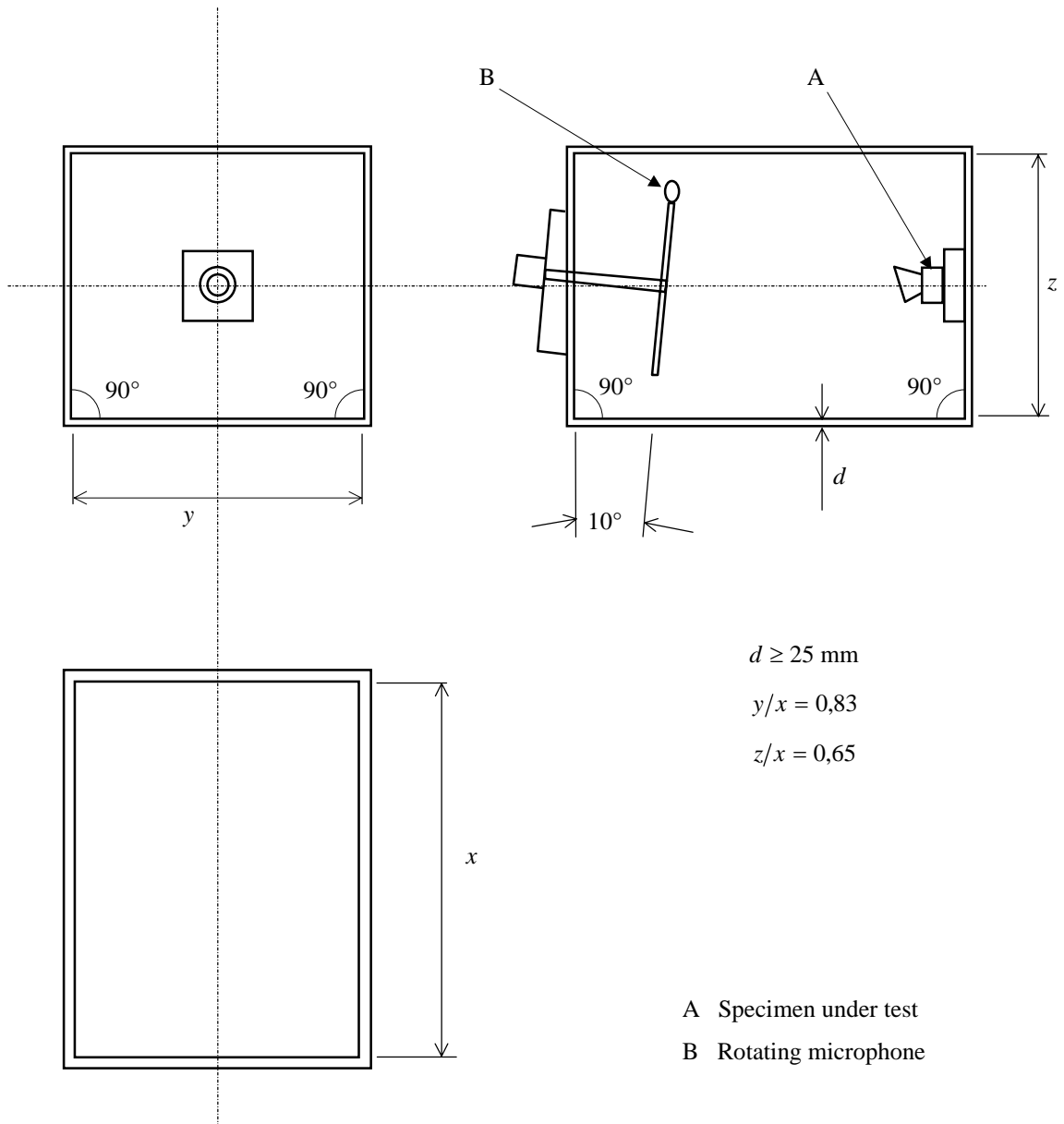

Figure B2 — Example of reverberation chamber as described in B.2.2 b)

Annex C
(normative)

Audible fire alarm devices – Voice sounders

C.1 Voice sounder

A voice sounder is an audible fire alarm device that contains all the necessary components to generate and broadcast recorded voice messages.

C.2 General requirements

The voice sounder shall meet all of the requirements applicable to audible fire alarm devices – sounders, specified in Clause 4.

C.3 Additional requirements

C.3.1 Attention drawing signal and message broadcast sequences

C.3.1.1 The voice sounder shall be capable of producing an audible attention-drawing signal and a broadcast message or messages.

All messages related to fire safety shall be declared by the manufacturer and shall be considered by the testing authority. The worst case message(s) shall be subject to compliance testing.

NOTE When selecting the worst case message, message length, loudness and repetition timing should be considered.

C.3.1.2 For messages that require immediate action, the attention drawing signal and message sequence broadcast by the device shall be within the limits given in Table C.1.

NOTE For other messages, it is permitted to extend either or both the silence period after the broadcast message and the period within which the message is repeated.

C.3.1.3 Access to the message recording function shall be restricted as described in 4.5.4.

NOTE Persons trained in the proper use of microphones should be used to record the messages. The recordings should be made in a room with a controlled acoustic environment having an ambient noise level not greater than 30 dBA and a reverberation time not greater than 0,5 s from 150 Hz to 10 kHz.

Table C.1 — Tone and message sequence

Attention-drawing signal – lasting 2 s to 10 s
followed by:
Brief silence – lasting 0,25 s to 2 s
followed by:
Broadcast message ^{a)}
followed by:
Silence ^{b)} – lasting 0,25 s to 5 s
^{a)} The time between the start of each repeated message shall not exceed 30 s. ^{b)} The periods of silence may need to be longer than indicated in certain circumstances, for example in spaces with long reverberation times, but shall not be such that the time between the start of each repeated message exceeds 30 s.

A2

A₂ C.3.2 *Synchronisation (option with requirements)*

Voice sounders may interact acoustically when they are installed in close proximity. To prevent this, voice sounders may have provision for synchronising the attention drawing signal and message sequence with that of other devices of the same type. In this case, the requirements of the test described in C.5.3 shall be met.

When power interruption is used for synchronisation purpose, this shall not adversely affect the attention drawing signal or the voice message.

NOTE Synchronisation can be achieved by internal circuitry, the addition of a trigger wire connected between devices or by other means as defined by the manufacturer.

C.3.3 *Marking and data*

In addition to the data required by 4.6.2 the following shall be provided:

- a) full instructions on the method of message recording and loading or, if it is not possible for the user to record and load messages, a statement to this effect;
- b) information concerning the method of synchronisation or, if synchronisation is not an option, a statement that the devices may only be installed in positions where they do not interact acoustically with other devices of the same type.

C.4 **General testing**

C.4.1 *Test schedule*

The voice sander shall be subjected to the schedule of tests given in 5.1.

C.4.2 *Operational performance*

Only the attention-drawing signal shall be measured when the device is tested for operational performance to 5.3.

C.5 **Additional testing for voice sounders**

C.5.1 *Broadcast message performance*

C.5.1.1 *Object of the test*

To verify that the output level of the broadcast message in relation to the output level of the attention-drawing signal is sufficient.

C.5.1.2 *Test procedure*

The following test procedure shall be applied:

- a) the sound level of the specimen to be tested shall be measured in free field conditions using the test method described in Annex A;
- b) while the attention-drawing signal of the device is being tested for operational performance to 5.3, an additional measurement shall be taken to measure the sound level of the broadcast message;
- c) the sound level of the broadcast message shall be measured as equivalent sound pressure level, L_{eq} , over a 1 min period;
- d) the sound levels of both the attention-drawing signal and the broadcast message shall be measured at an angle of 15° off the axis of the specimen being tested (see Figures A.2 and A.3).

C.5.1.3 *Test requirements*

The voice sander shall be deemed to comply with the requirement of this clause if the sound level of the broadcast message, L_{eq} , is not more than 6 dB below the sound level of the attention-drawing signal.

NOTE The difference in the measurement of the sound levels of the broadcast message and that of the attention-drawing signal will vary depending on the frequency of the attention-drawing signal. **A₂**

A₂ C.5.2 *Attention-drawing signal silence message sequence timing*

C.5.2.1 *Object of the test*

To verify that the duration of the attention-drawing signal, the duration of the silence period between the end of the attention-drawing signal and the start of the broadcast message, the duration of the silence period between the end of the message and the start of the next attention-drawing signal and the total duration of the complete attention-drawing signal, silence, message sequence are within the required limits.

C.5.2.2 *Test procedure*

The following test procedure shall be applied:

- a) the specimen shall be connected to a suitable power supply which shall be set in turn to the maximum and minimum supply parameters declared by the manufacturer (see 4.6.2a);
- b) the duration of the tone, the two silence periods and the complete attention-drawing signal/silence/message sequence shall in turn be measured 6 times using a timing instrument accurate to 0,01 s.

C.5.2.3 *Test requirements*

The voice sounder shall be deemed to comply with the requirement of this sub-clause if the measurements of C.5.2.2 are within the limits specified in Table C.1.

C.5.3 *Message synchronisation testing option with requirements*

C.5.3.1 *Object of the test*

To show the ability of voice sounders to remain synchronised over a period of 30 min after they have been powered ON.

C.5.3.2 *Test procedure*

The following test procedure shall be applied:

- a) two voice sounders shall be placed in two separate areas that have no significant acoustic interaction, have a low background noise level and have low reverberation;
- b) each specimen to be tested shall be powered from suitable power supply equipment (see 5.1.2). The specimens shall be connected to a suitable power supply which shall be set in turn to the maximum and minimum supply parameters declared by the manufacturer (see 4.6.2a);
- c) if it is required by their mode of synchronisation, a trigger wire shall be connected between the two specimens under test;
- d) identical microphones shall be placed at a distance of 100 mm in front of each specimen under test. The two microphones shall be connected to a dual channel measuring instrument (see Figure C.1);
- e) the two specimens being tested shall be powered or their operation shall be triggered by the control equipment. The signal produced by the two specimens shall be compared at the start and finish of the broadcast message. The time differences between the signals at the start of the broadcast and at the end of the broadcast shall be measured and recorded. These shall be designated ΔT_S and ΔT_F respectively;
- f) the measurements shall be made when the devices are first powered ON and then, thereafter, every five minutes until the devices have been operating for 30 min. If the supply to the devices is interrupted at any point during the 30 min test period, then the test sequence shall be repeated over a new period of 30 min. **A₂**

A2 C.5.3.3 Test requirements

The voice sounder shall be deemed to comply with the requirements of this clause if the measured time differences between the two devices under test are within the following limits:

- a) at the start of the 30 min test, ΔT_S and T_F are equal to or less than 0,02 s, and
- b) for all measurements over the 30 min test, ΔT_S and T_F are equal to or less than 0,05 s.

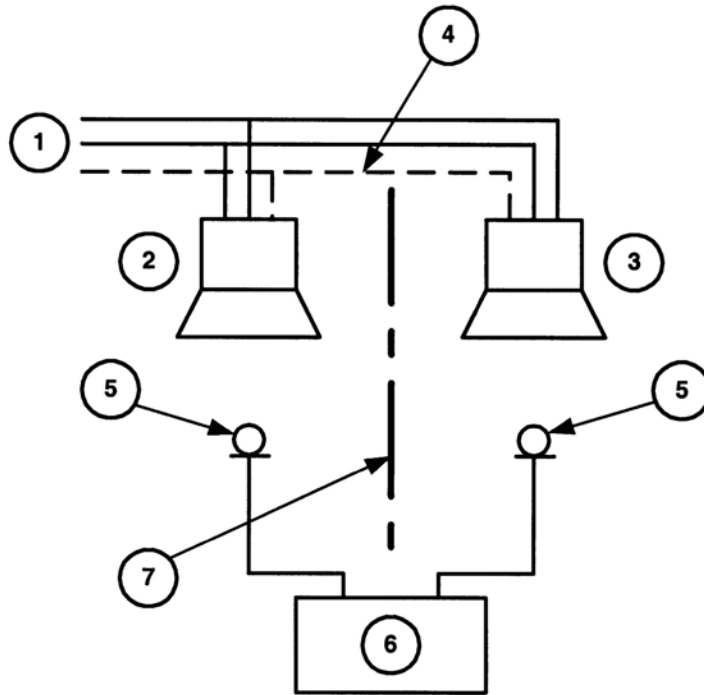

Key

- 1 power supply/control equipment
- 2 voice sounder under test No. 1
- 3 voice sounder under test No. 2
- 4 trigger wire (if required)
- 5 microphones
- 6 dual channel signal measurement/recording instrument
- 7 acoustic screen

Figure C.1 — Test arrangement to measure synchronisation **A2**

A₂ Annex ZA
(informative)

Clauses of this European Standard addressing the provisions of the EU Construction Products Directive (89/106/EEC)

A₂ ZA.1 Scope and relevant clauses

This European Standard has been prepared under Mandate M/109 given to CEN by the European Commission and the European Free Trade Association.

The clauses of this European Standard, shown in this annex, meet the requirements of the mandate given under the EU Construction Products Directive (89/106/EEC).

Compliance with these clauses confers a presumption of fitness (as defined by the Construction Products Directive) of the construction product covered by this European Standard for its intended use according to clause 1 (Scope) of this standard; reference shall be made to the information given with the CE marking (see clause ZA.3).

WARNING — Other requirements and other EU Directives may be applicable to the products falling within the scope of this standard.

NOTE In addition to any specific clauses relating to dangerous substances contained in this standard, there may be other requirements applicable to the products falling within its scope (e.g. transposed European legislation and national laws, regulations and administrative provisions). These requirements need also to be complied with, when and where they apply. An informative database of European and national provisions on dangerous substances is available at the Construction web site on EUROPA (accessed through <http://europa.eu.int/comm/enterprise/construction/internal/dangsub/dangmain.htm>).

This Annex ZA has the same scope, in relation to the products covered, as clause 1 of this standard. This annex establishes the conditions for the CE marking of sounders intended for the use shown below and identifies the relevant clauses applicable.

Construction Product:	Fire detection and fire alarm systems — Alarm devices — Sounders. buildings.
Intended use:	Fire safety. A₂

Table ZA.1 — Relevant clauses

Essential characteristics	Clauses in this European Standard	Mandated level(s) or class(es)	Notes
Performance under fire condition	4.2, 4.3, 5.2, 5.3, C.3.1, C.3.2, C.5.1, C.5.2, C.5.3	None	a) b)
Operational reliability	4.4, 4.5, 4.6, 5.4, C4		a)
Durability of operational reliability: temperature resistance	5.5, 5.6, 5.7, 5.8, 5.9		c)
Durability of operational reliability: humidity resistance	5.8, 5.9, 5.10		c)
Durability of operational reliability: corrosion resistance	5.11		
Durability of operational reliability: shock and vibration resistance	5.12 to 5.15		
Durability of operational reliability; electrical stability	5.16		d)
Durability of operational reliability: resistance to ingress	5.17		
a) C.3, C.4, C.5.1, C.5.2 and C.5.3 apply only to voice sounders. b) C.3.2 and C.5.3 apply only to voice sounders with the message synchronisation option. c) 5.6 and 5.10 applies only to outdoor sounders or outdoor voice sounders. d) 5.16 applies only to sounders or voice sounders with active electronic components.			

ZA.2 Procedures for the attestation of conformity of sounders covered by this standard

ZA.2.1 System of attestation of conformity

The mandate requires that the attestation of conformity system to be applied shall be that shown in Table ZA.2.

Table ZA.2 — Attestation of conformity system

Product	Intended use	Levels or classes	Attestation of conformity system
Fire detection and fire alarm systems: – Components of voice alarm systems – Sounders.	Fire safety	None	1
System 1: See CPD Annex III.2.(i), without audit-testing of samples by the notified body.			



A2 ZA.2.2 *Evaluation of conformity*

ZA.2.2.1 *General*

The evaluation of conformity of the product with the requirements of this European Standard shall be demonstrated by:

- a) Tasks to be provided by the manufacturer:
 - 1) factory production control,
 - 2) testing of samples by the manufacturer in accordance with a prescribed test plan.
- b) Tasks to be undertaken under the responsibility of a Notified Product Certification Body:
 - 1) type testing of the product,
 - 2) initial inspection of the factory and factory production control,
 - 3) periodic surveillance, assessment and approval of the factory production control.

NOTE The manufacturer is a natural or legal person, who places the product on the market under his own name. Normally, the manufacturer designs and manufactures the product himself. As a first alternative, he may have it designed, manufactured, assembled, packed, processed or labelled by subcontracting. As a second alternative he may assemble, pack, process, or label ready-made products.

The manufacturer shall ensure:

- that the initial type testing in accordance with this European Standard is initiated and carried out under the responsibility of a notified product certification body, and
- that the product continuously complies with the initial type testing samples, for which compliance with the European Standard in question has been verified.

He shall always retain the overall control and shall have the necessary competence to take the responsibility for the product. The manufacturer shall be fully responsible for the conformity of the product to all relevant regulatory requirements.

ZA.2.2.2 *Type testing*

ZA.2.2.2.1 Type testing shall be performed to demonstrate conformity with this European Standard.

Type testing of the product shall be carried out in accordance with the clauses shown in Table ZA.1, except as described in ZA.2.2.2.2 and ZA.2.2.2.3.

ZA.2.2.2.2 Tests previously performed, such as type tests for product certification, may be taken into account providing that they were made to the same or a more rigorous test method under the same system of attestation of conformity as required by this standard on the same product or products of similar design, construction and functionality, such that the results are applicable to the product in question.

NOTE Same system of attestation of conformity means testing by an independent third party under the responsibility of a product certification body which is now a notified product certification body.

ZA.2.2.2.3 Where one or more characteristics are the same for products with similar design, construction and functionality, then the results of tests for these characteristics on one product may be applied to the other similar product or products.

ZA.2.2.2.4 Test samples shall be representative of the normal production. If the test samples are prototypes, they shall be representative of the intended future production and shall be selected by the manufacturer.

NOTE In the case of prototypes and third party certification, this means that it is the manufacturer not the product certification body who is responsible for selecting the samples. During the initial inspection of the factory and of the factory production control (see ZA.2.2.3.4), it is verified that the type tested samples are representative of the product being produced.

ZA.2.2.2.5 All type testing and its results shall be documented in a test report. All test reports shall be retained by the manufacturer for at least ten years after the last date of production of the product to which they relate. **A2**

A2 ZA.2.2.3 *Factory production control*

ZA.2.2.3.1 General

Factory production control is the permanent internal control of production exercised by the manufacturer.

All the elements, requirements and provisions adopted by the manufacturer shall be documented in a systematic manner in the form of written policies and procedures. This production control system documentation shall ensure a common understanding of conformity evaluation and enable the achievement of the required product characteristics and the effective operation of the production control system to be checked.

Factory production control therefore brings together operational techniques and all measures allowing maintenance and control of the conformity of the product with its technical specifications. Its implementation may be achieved by controls and tests on measuring equipment, raw materials and constituents, processes, machines and manufacturing equipment and finished products, including material properties in components, and by making use of the results thus obtained.

ZA.2.2.3.2 General requirements

The manufacturer shall establish, document and maintain an FPC system to ensure that the products placed on the market conform to the stated performance characteristics and the samples subjected to type testing.

Where subcontracting takes place, the manufacturer shall retain the overall control of the product and ensure that he receives all the information that is necessary to fulfil his responsibilities according to the European Standard in question. If the manufacturer has part of the product designed, manufactured, assembled, packed, processed and/or labelled by subcontracting, the FPC of the subcontractor may be taken into account, where appropriate, for the product in question. The manufacturer who subcontracts all of his activities may in no circumstances pass these responsibilities on to a subcontractor.

The FPC system shall fulfil the requirements as described in the following clauses of EN ISO 9001:2000, where applicable:

- 4.2 except 4.2.1a),
- 5.1 e), 5.5.1, 5.5.2,
- Clause 6,
- 7.1 except 7.1 a), 7.2.3 c), 7.4, 7.5, 7.6,
- 8.2.3, 8.2.4, 8.3, 8.5.2.

The FPC system may be part of an existing quality management system, (e.g. in accordance with EN ISO 9001:2000), the scope of which covers the manufacture of the product.

Where a quality management system is certified in accordance with EN ISO 9001:2000, by a certification body which is now a notified body, then the assessment reports of this quality management system should be taken into account with respect to these clauses.

ZA.2.2.3.3 Product specific requirements

The FPC system shall:

- address this European Standard, and
- ensure that the products placed on the market conform to the stated performance characteristics.

The FPC system shall include a product specific FPC or quality plan, which identifies procedures to demonstrate conformity of the product at appropriate stages, i.e.:

- a) the controls and tests to be carried out prior to and/or during manufacture according to a frequency laid down, and/or
- b) the verifications and tests to be carried out on finished products according to a frequency laid down. **A2**

A₂ If the manufacturer uses only finished products, the operations under b) shall lead to an equivalent level of conformity of the product as if FPC had been carried out during the production.

If the manufacturer carries out parts of the production himself, the operations under b) may be reduced and partly replaced by operations under a). Generally, the more parts of the production that are carried out by the manufacturer, the more operations under b) may be replaced by operations under a). In any case the operation shall lead to an equivalent level of conformity of the product as if FPC had been carried out during the production.

NOTE Depending on the specific case, it can be necessary to carry out the operations referred to under a) and b), only the operations under a) or only those under b).

The operations under a) centre as much on the intermediate states of the product as on manufacturing machines and their adjustment, and measuring equipment etc. These controls and tests and their frequency shall be chosen based on product type and composition, the manufacturing process and its complexity, the sensitivity of product features to variations in manufacturing parameters etc.

The manufacturer shall establish and maintain records that provide evidence that the production has been sampled and tested. These records shall show clearly whether the production has satisfied the defined acceptance criteria and shall be available for at least three years. These records shall be available for inspection.

Where the product fails to satisfy the acceptance measures, the provisions for non-conforming products shall apply, the necessary corrective action shall immediately be taken and the products or batches not conforming shall be isolated and properly identified. Once the fault has been corrected, the test or verification in question shall be repeated.

The results of controls and tests shall be properly recorded. The product description, date of manufacture, test method adopted, test results and acceptance criteria shall be entered in the records under the signature of the person responsible for the control/test. With regard to any control result not meeting the requirements of this European Standard, the corrective measures taken to rectify the situation (e.g. a further test carried out, modification of manufacturing process, discarding or putting right of product) shall be indicated in the records.

Individual products or batches of products and the related manufacturing documentation shall be completely identifiable and retraceable.

ZA.2.2.3.4 Initial inspection of factory and FPC

Initial inspection of FPC shall be carried out when the production process has been finalised and preferably in operation. The factory and FPC documentation shall be assessed to verify that the requirements of ZA.2.2.3.1 and ZA.2.2.3.2 are fulfilled.

In the assessment it shall be verified:

- a) that all resources necessary for the achievement of the product characteristics required by this European Standard are or will be available, and
- b) that the FPC procedures in accordance with the FPC documentation are or will be implemented and followed in practice, and
- c) that the product complies or will comply with the initial type testing samples, for which compliance with this European Standard has been verified.

All locations where final assembly or at least final testing of the relevant product is performed, shall be assessed to verify that the above conditions a) to c) are in place.

If the FPC system covers more than one product, production line or production process, and it is verified that the general requirements are fulfilled when assessing one product, production line or production process, then the assessment of the general requirements does not need to be repeated when assessing the FPC for another product, production line or production process.

Provided that the production process is similar, assessments previously performed in accordance with the provisions of this standard may be taken into account providing that they were made to the same system of attestation of conformity on the same product or products of similar design, construction and functionality, such that the results may be considered applicable to the product in question.

NOTE Same system of attestation of conformity means inspection of FPC by an independent third party under the responsibility of a product certification body which is now a notified product certification body.

All assessments and their results shall be documented in a report. **A₂**

A₂ ZA.2.2.3.5 Periodic surveillance of FPC

Surveillance of the FPC shall be undertaken once a year.

The surveillance of the FPC shall include a review of the quality plan(s) and production processes(s) for each product to determine if any changes have been made since the last assessment or surveillance and the significance of any changes shall be assessed.

Checks shall be made to ensure that the quality plans are still correctly implemented and that the production equipment is still correctly maintained and calibrated.

The records of tests and measurement made during the production process and to finished products shall be reviewed to ensure that the values obtained still correspond with those values for the samples submitted to type testing and that the correct actions have been taken for non-compliant devices.

The surveillance of the FPC may be carried out as part of a surveillance or reassessment of a quality management system (e.g. in accordance with EN ISO 9001:2000).

ZA.2.2.4 Procedure for modifications

If modifications are made to the product, production process or FPC system that could affect any of the product characteristics required by this standard, then all characteristics covered by the clauses shown in Table ZA.1, which may be changed by the modification, shall be subject to type testing or engineering evaluation, except as described in ZA.2.2.2.3 and ZA.2.2.2.4. Where relevant, a reassessment of the factory and of the FPC system shall be performed for those aspects, which may be affected by the modification.

All assessments and their results shall be documented in a report.

ZA.3 CE marking and labelling and accompanying documentation

The manufacturer, or his authorised representative established in the EEA, is responsible for the affixing of the CE marking. The CE-marking symbol (in accordance with Directive 93/68/EEC) shall be placed on the product and be accompanied by the number of the EC certificate of conformity and the Notified Product Certification Body number. If the Notified Body number is included as part of the number of the EC certificate of conformity, then the number of the EC certificate of conformity is sufficient.

The CE marking symbol shall in addition be shown on the accompanying commercial documentation supplemented by:

- 1) identification number of the Notified Product Certification Body,
- 2) name or identifying mark and registered address of the manufacturer,
- 3) last two digits of the year in which the marking was affixed,
- 4) number of the EC certificate of conformity,
- 5) reference to this European Standard (EN 54-3), its date and any amendments,
- 6) description of the construction product (i.e. sounder, or voice sounder, for fire detection and fire alarm systems for buildings),
- 7) type/model designation of the product,
- 8) optional function with requirements, if used (see C.3.2),
- 9) other information required by 4.6.2 and C.3.3 or a reference to a document, which shall be uniquely identifiable and available from the manufacturer, containing this information.

NOTE Reference to a separate document is permitted only where the quantity of information would be so large that it could not practically be included in the commercial documentation accompanying the product.

Where the product exceeds the minimum performance levels stated in this standard, and where the manufacturer so desires, the CE marking may be accompanied by an indication of the parameter(s) concerned and the actual test result(s). **A₂**

A2 Figure ZA.1 gives an example of the CE marking information given on the accompanying commercial documentation.

 0123
AnyCo Ltd, P.O. Box 21, B1050 06 0123 – CPD – 001
EN 54-3 Alarm devices – Sounder Type B: For outdoor use ABC 123 Other technical data: see Doc.123/2006 held by the manufacturer

Figure ZA.1 — Example of CE marking information in the accompanying commercial documentation

ZA.4 EC certificate and declaration of conformity

The manufacturer, or his authorised representative established in the EEA, shall prepare and retain a declaration of conformity, which authorises the affixing of the CE marking. This declaration shall include:

- name and address of the manufacturer, or his authorised representative established in the EEA, and the place of production,

NOTE 1 The manufacturer may also be the person responsible for placing the product onto the EEA market, if he takes responsibility for CE marking.

- description of the construction product (i.e. sounder, or voice sounder, for fire detection and fire alarm systems for buildings) and a copy of the information accompanying the CE marking,

NOTE 2 Where some of the information required for the Declaration is already given in the CE marking information; it does not need to be repeated.

- type/model designation of the product,
- provisions to which the product conforms (i.e. Annex ZA of this EN),
- any particular conditions applicable to the use of the product (if necessary),
- name and address (or identification number) of the Notified Product Certification Body,
- name of and position held by the person empowered to sign the declaration on behalf of the manufacturer or of his authorized representative. **A2**

A2 The declaration shall contain a certificate of conformity with the following information:

- name and address of the Notified Product Certification Body,
- certificate number,
- name and address of the manufacturer, or his authorised representative established in the EEA,
- description of the construction product (i.e. sounder, or voice sounder, for fire detection and fire alarm systems for buildings),
- type/model designation of the product,
- provisions to which the product conforms (i.e. Annex ZA of this EN),
- any particular conditions applicable to the use of the product (if necessary),
- any conditions of validity of the certificate, where applicable,
- name of and position held by the person empowered to sign the certificate.

The above-mentioned declaration and certificate shall be presented (if requested) in the language or languages accepted in the Member State in which the product is to be used. **A2**

Ⓐ Bibliography

EN ISO 9001, *Quality management systems — Requirements (ISO 9001:2000)*. Ⓐ